

# STANDARD FEATURES

## AVAILABLE ON ALL UNITS

### SAFETY Highly Accommodating Front-Mounted Hose Reel

- 270° rotation, 180° rotation fully retracted
- Capable of 1000' of 1" diameter sewer hose
- Extends 18"

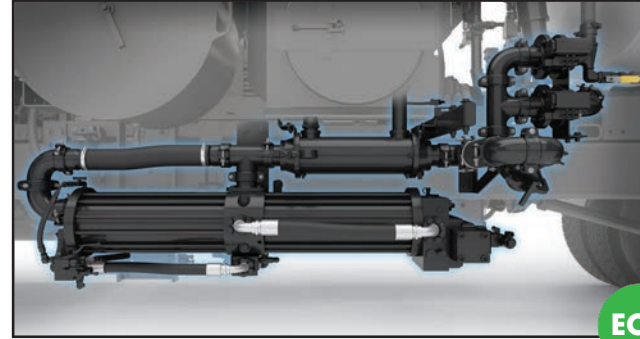

### Advanced Water Pump

- Pressure sensing, double acting, single piston pump, powered by pressure & flow compensating hydraulic system
- 1:1 oil to water ratio
- Designed capacity of 100 gpm and 3000 psi
- Does not need to be removed from chassis for service



### Precision Controls

- Ability to run water pump with or without vacuum
- LED panel lights enables readability in all environments at 1000 nits
- Unit Self Diagnostic

### Single Engine Design

- All Camel models feature a single engine design which offers:
- Lighter Weight
  - Up to 40% Less in Fuel Use
  - 15% Lower Operating RPM

### Additional Standard Features

- Safety**
- Backup Camera
  - Body Up Alarm
  - Boom Up Alarm
  - Debris Body Safety Prop
  - Safety Cones
  - Sewer Hose Containment Shield
  - Tailgate Alarm
  - Tailgate Safety Props
- Vacuum System**
- Hot Shift Transfer Case
  - Positive Displacement Blower
  - Vacuum Blower: 3600 cfm
- Water System**
- Air Purge
  - Antifreeze System
  - Dual Accumulators
  - Dual Hydraulic Cooling
  - Water Tank; rotationally molded, non-cross linked, polyethylene
- Boom System**
- 8" Hydraulic Boom with 8' Hydraulic Extension
  - 1000lb Boom Lifting Capacity
  - 217° of Rotation
- Tailgate**
- (4) Adjustable Hydraulic Wedge Pins
  - Hydraulic Powered Tailgate
- Debris Body**
- (1) Centrifugal Cyclone Separator: 44,000 cubic inches
  - Exterior Tank Front Mounted Level Gauge
  - Industrial Powder Coat Finish; White
  - Internal Debris Tank Flush Out System
  - Modular Designed Full Length Subframe
  - Quick Release Door less than 50" off the ground
  - ¼" Thick Debris Body EXTEN Steel Construction

# OPTIONAL FEATURES

## AVAILABILITY VARIES

### Optional Features

- Fully Automatic Powered Level Wind
- Hose Reel Tensioning
- Hydrant Fill with Auto Shut Off
- Lighting Packages
- Multiple Axles
- Signboards
- Splash Shield
- Tool Boxes
- Vacuum Blower Options up to 5500 cfm
- Winter Recirculation
- Wireless Remote

### Increase your Payload

Adding the **Pusher Axle** stretches chassis length by 12" while increasing payload capacity.



### OPTION ACCULEVEL Load Sensor System



### 20/20 Vision for your Camel

The **ACCULEVEL**® is an innovative radar debris body level sensor that shows the true debris level. This is digitally displayed on the front mounted control panel for easy operating viewing. By monitoring this, the operator can choose to continue working, dewater or dump debris.

### OPTION Hydro Excavation

Adding the **Hydro Ex Package** to your truck will transform your Combination Sewer Cleaner into a Hydro Excavator. The package comes with (1) water handgun, (1) dig tube with nonconducting cuff, (1) rebuildable urethane coated nozzle and other accessories to turn your Camel into a 3 in 1 mobile unit. Clean a sewer line in the morning and unearth utility lines in the afternoon.



0222

# Super Products®

# CAMEL® MAX SERIES

## COMBINATION SEWER CLEANERS



**MAXIMUM SAFETY.**  
**MAXIMUM RELIABILITY.**  
**MAXIMUM PERFORMANCE.**

800.837.9711 • WWW.SUPERPRODUCTS.COM



## The Most Versatile Combo in the Industry

Jet • Vacuum • Hydro Excavate • Wastewater Recycle • Dump • Eject

## AVAILABLE MODELS



Camel 900 Dump

- > Debris Body: 9 yards
- > Vacuum Blower: 3600 cfm
- > Water Capacity: 1000 gallons
- > Debris Body: 9 yards
- > Single Axle
- > Length: 35' 6" (approx.)
- > Height: 11' 6" (approx.)



Camel 1200 Dump  
Camel 1200 Eject  
Camel 1200 Wastewater Recycle

- > Debris Body: 12 yards
- > Vacuum Blower: 3600 cfm
- > Water Capacity: 1500 gallons
- > Tandem Axle
- > High Dump Body
- > Length: 38' 6" (approx.)
- > Height: 11' 11" (approx.)

\* Disclaimer: Product photos may include standard and/or optional features

## UNLOADING SYSTEMS: DUMP OR EJECTION

**Dump Unloading:** The dump unloading system uses a telescopic hydraulic cylinder to raise the body up to a 50° angle and gravity removes the debris. This unit has the capability to dump into a 42-inch container. The unit still maintains a low overhead height during normal operation and a low center of gravity for increased stability.

900  
and  
1200  
Dump



**Ejection Unloading:** The ejection unloading system is the industry's safest and most efficient removal of debris. The body raises to an 8.5° angle and the ejector plate quickly pushes out debris. This allows operators to have the only controlled way to dump into a 48-inch container without the need of additional containment products.

1200  
Eject  
and  
WWR  
SAFETY



## WASTEWATER RECYCLING: FILL IT ONCE & WORK ALL DAY

Super Products' wastewater recycling system enables operators to clean sewers without the use of fresh water.

SAVE  
WATER

Clean 3,000 feet of pipe a day;  
**SAVE 60,000 GALLONS**  
of water a week!

SAVE  
TIME

Longer onsite performance;  
**CLEAN 78% MORE**  
pipe a day!

> This equates to 2 extra work days!

1200  
WWR

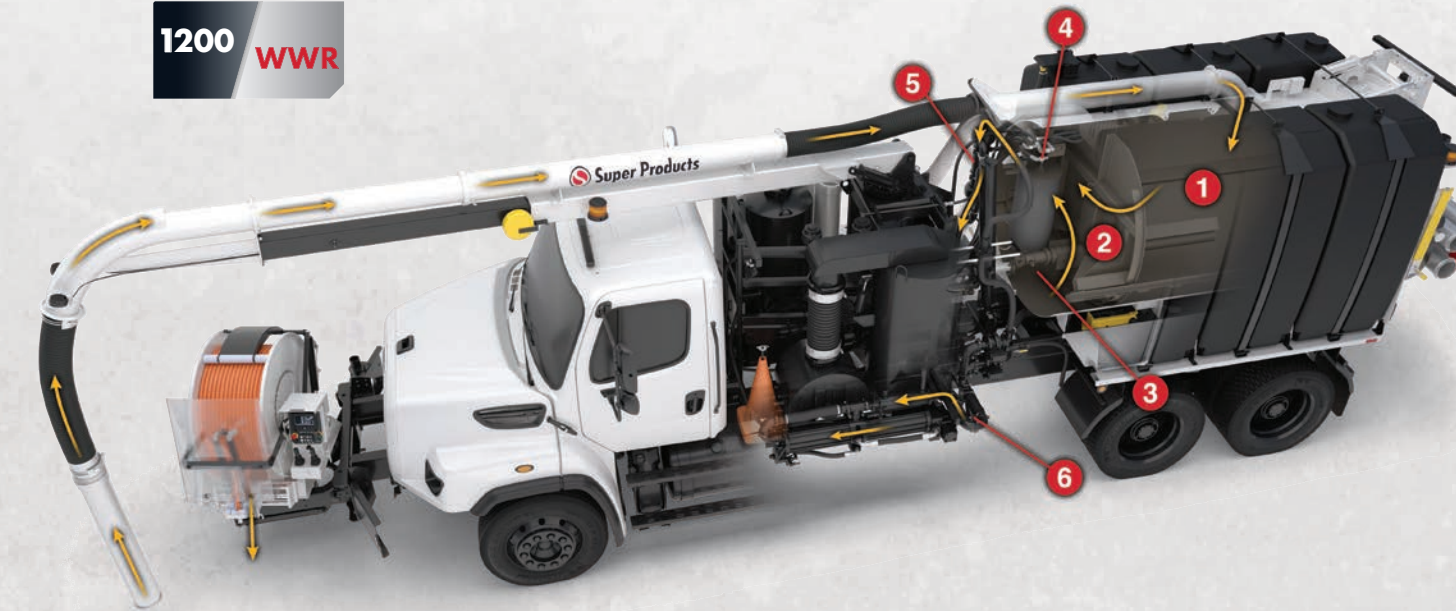

### 6 Stages of Wastewater Recycling

ECO

1. **Debris Tank** – Initial separation takes place as debris enters
2. **Ejector Plate** – Small clearances and passages allow liquids to pass to the bulkhead side, holding solids on the tailgate side
3. **Recycling Water Reservoir** – Controls water level on filter screen
4. **Stainless Steel Wedge Wire Filter** – Self-cleaning and oscillating
  - a. Constant low pressure spray bar uses recycled water to externally clean the screen
  - b. Intermittent high pressure spray bar uses fresh water to internally clean the screen
5. **Cyclone Separator** – Removes particles from the liquid
  - a. Includes an automatic continuous discharge of particles back into the debris body
6. **Y-Strainer with Stainless Steel Element** – Filters the liquid prior to the high pressure water pump