



# ALLEYGATOR ZERO

## THE IDEAL CHOICE FOR ORGANICS COLLECTION

- 20 yd<sup>3</sup> to 30 yd<sup>3</sup> body sizes available
- Up to 700 lbs/yd<sup>3</sup> compaction
- Pendulum packing system does not require guide rails, tracks, a follower panel or clean out doors
- Self-cleaning hopper eliminates the need for daily cleanout of hopper
- Packing cylinders located outside of the hopper; easy to access and safe from debris and contamination
- Full tailgate seal and liquid tight hopper ideal for wet organics
- Best in class Right Hand™ arm with 12 foot reach and 1000 lb lifting capacity also available
- Zero Kick-Out arm perfect for alleys and tight spots
- Fully integrated Labrie CNG systems - roof, tailgate and back of cab mount - 50 to 96 DGE available

### Body Specifications

Body Floor	3/16" A1011 80,000psi
Body Sides	10ga A1011 80,000psi
Body Roof	10ga A1011 80,000psi
Tailgate	10ga A1011 80,000psi

### Hopper Specifications

Hopper Size (yd <sup>3</sup> )	3.3
Hopper Width	64"
Hopper Floor	5/16" AR400 140,000 psi
Hopper Sides (lower)	5/16" AR450 175,000psi

### Cylinder Specifications (Zero Kick-Out Arm)

Packer Cylinders	5" bore x 3-1/2" rod x 18-1/2" stroke
Arm Extension Cylinder	1-1/2" bore x 1" rod x 66" stroke
Grabber Cylinders	1-1/2" bore x 3/4" rod x 8-1/4" stroke
Tailgate Cylinders	2-1/2" bore x 1-3/4" rod x 31" stroke
Body Lifting Cylinder (20-23 yd <sup>3</sup> bodies)	6-1/16" bore x 143-3/8" stroke
Body Lifting Cylinder (27-30 yd <sup>3</sup> bodies)	6-1/16" bore x 169-7/8" stroke

### Arm Specifications (Zero Kick-Out Arm)

Arm Lift Capacity	550 lbs
Arm Reach	84"
Swing out	0"
Arm Controls	Proportional joystick, electric over hydraulic

### Arm Specifications (Right-Hand™ Arm)

Arm Lift Capacity	1,000 lbs
Arm Reach	144"
Swing out	36"
Arm Controls	Proportional joystick, electric over hydraulic

### Packer Specifications

Compaction ratio (lbs/yd <sup>3</sup> )	700
Packer Width	63"
Packer Height	14"
Packer Face	5/16" AR400 140,000 psi
Packer Top	1/4" AR400 140,000 psi

### Hydraulic Specifications

Pump Make & Model	Dual Vane
Pump Capacity	BODY: 18 gpm@700 rpm; ARM: 18 gpm@700 rpm
Max. Operating Pressure	2,700 psi
Oil Reservoir	55 gal

Note: Specifications subject to change without notice





# ALLEYGATOR ZERO

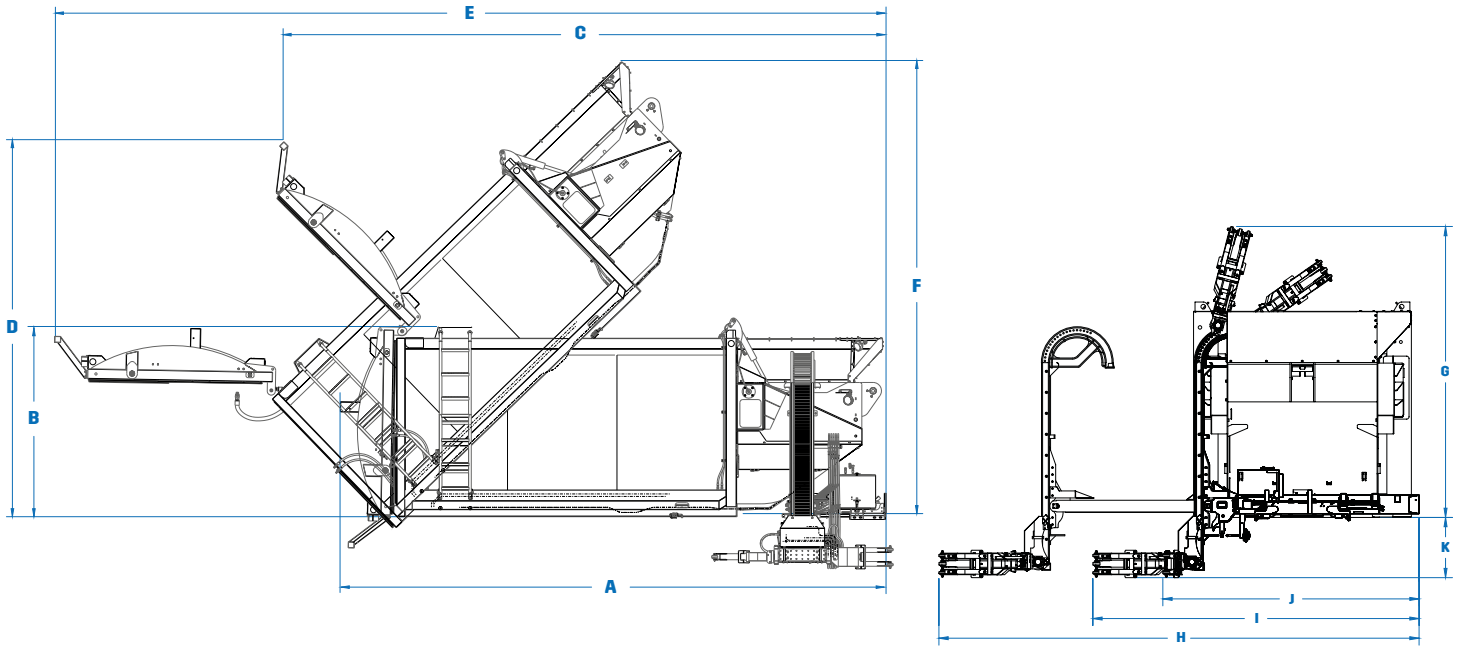

## Body Dimensions

	20yd <sup>3</sup> (20+0)	23yd <sup>3</sup> (20+3)	27yd <sup>3</sup> (27+0)	30yd <sup>3</sup> (27+3)
A. Overall Length, Tailgate Closed (in.)	230	249	268	287
Overall Width (in.)	102	102	102	102
B. Overall Height Above Frame, Tailgate Closed (in.)	94	94	94	94
C. Overall Length, Tailgate Open (in.)	262	262	300	300
D. Overall Height Above Frame, Tailgate Open (in.)	186	186	186	186
E. Overall Length, Dumping Position (in.)	373	373	411	411
F. Overall Height Above Frame, Dumping Position (in.)	200	200	227	227
G. Overall Height Above Frame When Dumping (in.)	125	125	125	125
H. Overall Width, Arm Out, Grabber Closed (in.)	206	206	206	206
I. Overall Width, Arm In, Grabber Closed (in.)	140	140	140	140
J. Overall Width, Arm In, Grabber Open (in.)	110	110	110	110
K. Distance between bottom of Grabber and chassis frame rail (in.)	26	26	26	26

## Performance Specifications (Zero Kick-Out Arm)

Arm In (72" reach)	2.6 sec @ 700 rpm
Arm In (84" reach)	3.0 sec @ 700 rpm
Arm Out (72in. reach)	3.9 sec @ 700 rpm
Arm Out (84" reach)	4.5 sec @ 700 rpm
Arm Up	3.0 - 4.0 sec @ 700 rpm
Arm Down	2.5 - 3.5 sec @ 700 rpm
Grabber Open	1.5 - 2.5 sec @ 700 rpm
Grabber Close	1.5 - 2.5 sec @ 700 rpm

Packer complete cycle	25 sec @ 700 rpm
Tailgate Open	17 sec @ 700 rpm
Tailgate Close (with Safety Flow limiter)	18 sec @ 700 rpm
Body Up (depending on body size)	75 sec @ 700 rpm
Body Down (depending on body size)	55 sec @ 700 rpm
Crusher panel Up	5 sec @ 700 rpm
Crusher panel Down	4 sec @ 700 rpm



labrieplus  
SERVICE & PARTS

DRIVE EXCELLENCE

labrie